

SPECIFICATIONS

NI PXI-2530B

128-Channel Reed Relay Multiplexer/Matrix

This document lists specifications for the NI PXI-2530B 128-channel multiplexer/matrix module (NI 2530B). All specifications are subject to change without notice. Visit ni.com/manuals for the most current specifications.

Topology	1-wire 128 x 1 multiplexer, 1-wire dual 64 x 1 multiplexer, 1-wire quad 32 x 1 multiplexer, 1-wire octal 16 x 1 multiplexer, 2-wire 64 x 1 multiplexer, 2-wire dual 32 x 1 multiplexer, 2-wire quad 16 x 1 multiplexer, 4-wire 32 x 1 multiplexer, 4-wire dual 16 x 1 multiplexer, 1-wire 4 x 32 matrix, 1-wire 8 x 16 matrix, 2-wire 4 x 16 matrix, independent
----------	--



Note The NI 2530B has eight interconnected banks of 1-wire 16×1 multiplexers. These multiplexers can be used in any combination with the independent topology.



Caution To ensure the specified EMC performance, operate this product only with shielded cables and accessories.



Caution Refer to the *Read Me First: Safety and Electromagnetic Compatibility* document for important safety and electromagnetic compatibility information. To obtain a copy of this document online, visit ni.com/manuals and search for the document title.

Related Information

[Refer to the NI Switches Help for detailed topology information.](#)

About These Specifications

Specifications characterize the warranted performance of the instrument under the stated operating conditions.

Typical Specifications are specifications met by the majority of the instrument under the stated operating conditions and are tested at 23 °C ambient temperature. Typical specifications are not warranted.

All voltages are specified in DC, AC_{pk}, or a combination unless otherwise specified.



Caution The protection provided by the NI 2530B can be impaired if it is used in a manner not described in this document.

Input Characteristics

Maximum switching voltage

Channel-to-channel	60 VDC, 30 VAC _{rms} , CAT I
Channel-to-ground	60 VDC, 30 VAC _{rms} , CAT I

Measurement Category I is for measurements performed on circuits not directly connected to the electrical distribution system referred to as *MAINS* voltage. MAINS is a hazardous live electrical supply system that powers equipment. This category is for measurements of voltages from specially protected secondary circuits. Such voltage measurements include signal levels, special equipment, limited-energy parts of equipment, circuits powered by regulated low-voltage sources, and electronics.



Caution Do not connect the NI 2530B to signals or use for measurements within Measurement Categories II, III, or IV.



Caution Measurement Categories CAT I and CAT O are equivalent. These test and measurement circuits are not intended for direct connection to the MAINS building installations of Measurement Categories CAT II, CAT III, or CAT IV.

Maximum current (per terminal or internal path)	0.4 A
Maximum switching power (per channel, resistive)	10 W
DC path resistance ¹ (channel-to-common)	
Initial	<2 Ω, typical
End-of-life	≥3 Ω, typical
Thermal EMF (1-wire configuration, channel-to-common)	<50 μV, typical

¹ Path resistance is a combination of relay contact resistance and trace resistance. Contact resistance typically remains low for the life of a relay. At the end of relay life, the contact resistance may rapidly rise above 3 Ω.

RF Performance Characteristics

Bandwidth (50 Ω system, 1-wire configuration referenced to 1WREF)

16×1 >19 MHz, typical

128×1 >12 MHz, typical

Channel-to-channel isolation (50 Ω system, 1-wire configuration referenced to 1WREF)

200 kHz >60 dB, typical

1 MHz >40 dB, typical

Dynamic Characteristics

Simultaneous drive limit 64 relays

Relay operate/release time 555 μ s



Note Certain applications may require additional time for proper settling.

Relay life (no load)

Mechanical $1 * 10^9$ cycles, typical

Electrical (resistive, <10 pF load)

10 V, 100 mA $1 * 10^8$ cycles, typical

25 V, 400 mA $5 * 10^6$ cycles, typical

60 V, 160 mA $1 * 10^6$ cycles, typical



Note Reed relays are highly susceptible to damage caused by switching capacitive and inductive loads. Capacitive loads can cause high inrush currents while inductive loads can cause high flyback voltages. The addition of appropriate resistive protection can greatly improve contact lifetime. For more information about adding protection circuitry to a capacitive load, visit ni.com/info and enter the Info Code `relaylifetime`. For information about inductive loads, enter the Info Code `relayflyback`.



Note The relays used in the NI 2530B are field replaceable.

Related Information

Refer to the NI Switches Help for information about including additional settling time, and replacing a failed relay.

Estimating Reed Relay Life on page 8

Trigger Characteristics

Input trigger	
Sources	PXI trigger lines 0 to 7, front panel
Minimum pulse width	150 ns
Front panel input voltage	
Minimum	-0.5 V
V _{IL} maximum	+0.7 V
V _{IH} minimum	+2.0 V
Nominal	+3.3 V
Maximum	+5.5 V



Note The NI 2530B can recognize trigger pulse widths less than 150 ns if you disable digital filtering.

Output trigger	
Destinations	PXI trigger lines 0 to 7, front panel
Pulse width	Programmable (1 μ s to 62 μ s)
Front panel nominal voltage	+3.3 V TTL, 8 mA

Related Information

[Refer to the NI Switches Help for information about disabling digital filtering.](#)

Physical Characteristics

Relay type	Reed
 Note NI advises against installing reed relay modules directly adjacent to an embedded controller with a magnetic hard drive because of the sensitivity of reed relays and the possibility of interference.	
Front panel connector	LFH matrix 50, 160 positions, female
PXI power requirement	4.2 W at 5 V, 1.2 W at 3.3 V
Dimensions (L \times W \times H)	3U, one slot, PXI/cPCI module, 21.6 \times 2.0 \times 13.0 cm (8.5 \times 0.8 \times 5.1 in.)
Weight	266 g (9.4 oz)

Environment

Operating temperature	0 °C to 55 °C
Storage temperature	-40 °C to 70 °C
Relative humidity	5% to 85%, noncondensing
Pollution Degree	2
Maximum altitude	2,000 m

Indoor use only.

Shock and Vibration

Operational Shock	30 g peak, half-sine, 11 ms pulse (Tested in accordance with IEC 60068-2-27. Test profile developed in accordance with MIL-PRF-28800F.)
-------------------	---

Random Vibration	
Operating	5 Hz to 500 Hz, 0.3 g _{rms}
Nonoperating	5 Hz to 500 Hz, 2.4 g _{rms} (Tested in accordance with IEC 60068-2-64. Nonoperating test profile exceeds the requirements of MIL-PRF-28800F, Class 3.)

Diagrams

Figure 1. NI 2530B Hardware Diagram (All Relays Open)

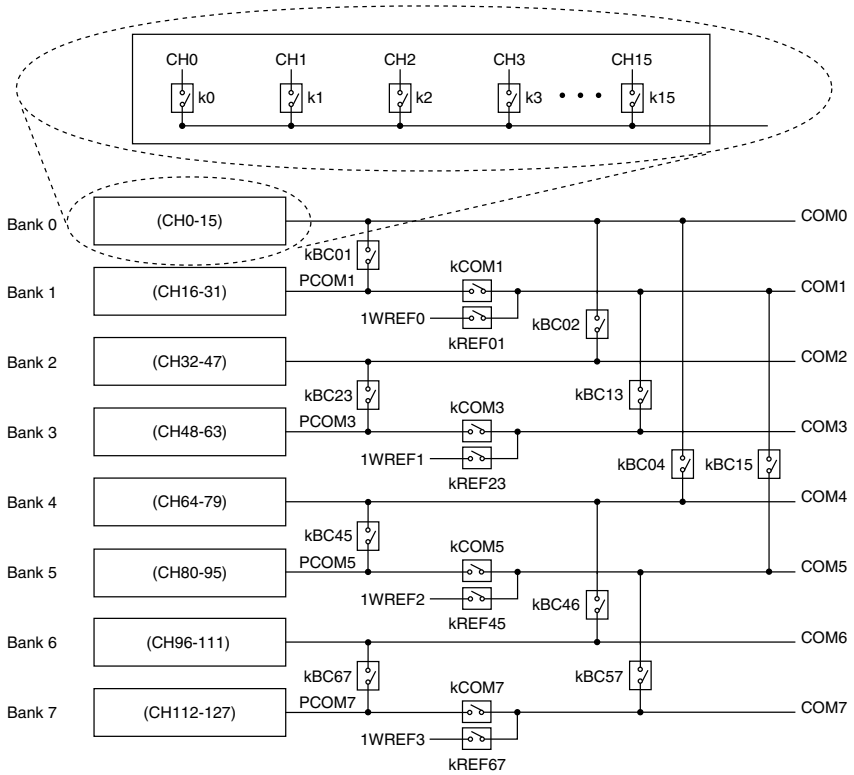
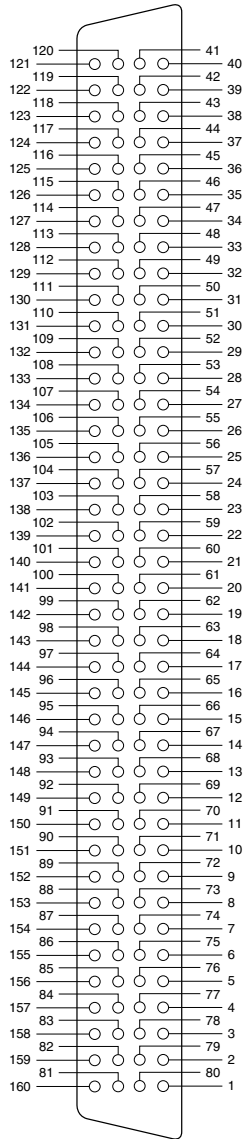

Figure 2. NI 2530B Connector Pinout



Related Information

For topology-specific connection information, refer to your device in the [NI Switches Help](#) and the installation instructions for any associated accessories or terminal blocks.

Accessories

Visit ni.com for more information about the following accessories.



Note The specifications listed in this document, including the safety and compliance certifications, also apply to the terminal blocks for the NI 2530B unless otherwise noted in the terminal block installation instructions.

Table 1. NI Accessories for the NI 2530B

Accessory	Part Number
NI TB-2630B terminal block (multiplexer)	781687-01
NI TB-2631B terminal block (4 × 32, 1-wire matrix, 4 × 16, 2-wire matrix)	781688-01
NI TB-2632B terminal block (8 × 16, 1-wire matrix)	781689-01
160-pin cable for the NI 2530B	781692-01



Note Refer to the terminal block installation instructions for signal connectivity options. Contact NI for custom terminal block designs.



Caution You must install mating connectors according to local safety codes and standards and according to the specifications provided by the connector manufacturer. You are responsible for verifying safety compliance of third-party connectors and their usage according to the relevant standard(s), including UL and CSA in North America and IEC and VDE in Europe.

Table 2. Third-Party Accessories for the NI 2530B

Accessory	Manufacturer	Manufacturer Part Number
Mating front panel connector, right-angle ²	Molex	51-25-1040

Estimating Reed Relay Life

Complete the following steps to estimate relay lifetimes using the nomograph:

1. Determine the peak voltage experienced across the relay while switching and mark this value on the *Volts* line.
2. Determine the sum of the DUT, cable, and instrumentation capacitances and mark this value on the *Load Capacitance* line.
3. Draw a straight line between both values.

² PCB mount, additional cover or enclosure required. Refer to previous safety caution.

The intersection points of this line and the *No Protection* and *50 Ω Protection* axes are the corresponding estimated relay lifetimes in cycles.

Estimating Reed Relay Life Example

The reed relay module is connected to a DMM through 1 meter of cable. The DMM and cable capacitances are 100 pF and 30 pF respectively. The maximum voltage switched across the relay is 50 V. Determine the estimated number of relay cycles with and without protection resistance.

Solution

The total load capacitance is the sum of the cable and DMM capacitance, which is 130 pF. Draw a line between the 50 V point on the *Volts* axis and 130 pF on the *Load Capacitance* axis.

The line drawn intersects the *Cycles* axes at approximately 500,000 on the *No Protection* axis and about 25,000,000 on the *50 Ω Protection* axis, as shown in the following figure. This series resistance should be placed as close as possible to the relay for maximum effect.

Figure 3. Reed Relay Lifetime Nomograph

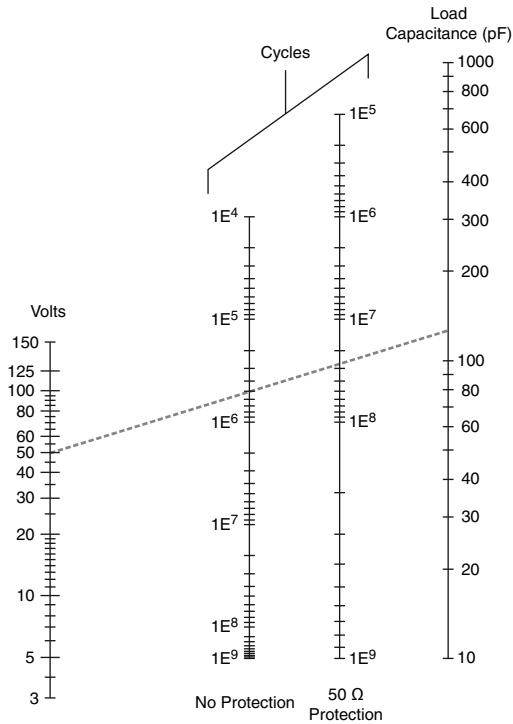

Compliance and Certifications

Safety

This product is designed to meet the requirements of the following electrical equipment safety standards for measurement, control, and laboratory use:

- IEC 61010-1, EN 61010-1
- UL 61010-1, CSA 61010-1



Note For UL and other safety certifications, refer to the product label or the [Online Product Certification](#) section.

Electromagnetic Compatibility

This product meets the requirements of the following EMC standards for sensitive electrical equipment for measurement, control, and laboratory use:

- EN 61326-2-1 (IEC 61326-2-1): Class A emissions; Basic immunity
- EN 55011 (CISPR 11): Group 1, Class A emissions
- AS/NZS CISPR 11: Group 1, Class A emissions
- FCC 47 CFR Part 15B: Class A emissions
- ICES-001: Class A emissions



Note In the United States (per FCC 47 CFR), Class A equipment is intended for use in commercial, light-industrial, and heavy-industrial locations. In Europe, Canada, Australia and New Zealand (per CISPR 11) Class A equipment is intended for use only in heavy-industrial locations.



Note Group 1 equipment (per CISPR 11) is any industrial, scientific, or medical equipment that does not intentionally generate radio frequency energy for the treatment of material or inspection/analysis purposes.



Note For EMC declarations and certifications, and additional information, refer to the [Online Product Certification](#) section.

CE Compliance

This product meets the essential requirements of applicable European Directives, as follows:

- 2014/35/EU; Low-Voltage Directive (safety)
- 2014/30/EU; Electromagnetic Compatibility Directive (EMC)

Online Product Certification

Refer to the product Declaration of Conformity (DoC) for additional regulatory compliance information. To obtain product certifications and the DoC for this product, visit [ni.com/certification](#), search by model number or product line, and click the appropriate link in the Certification column.

Environmental Management

NI is committed to designing and manufacturing products in an environmentally responsible manner. NI recognizes that eliminating certain hazardous substances from our products is beneficial to the environment and to NI customers.

For additional environmental information, refer to the *Minimize Our Environmental Impact* web page at ni.com/environment. This page contains the environmental regulations and directives with which NI complies, as well as other environmental information not included in this document.

Waste Electrical and Electronic Equipment (WEEE)



EU Customers At the end of the product life cycle, all NI products must be disposed of according to local laws and regulations. For more information about how to recycle NI products in your region, visit ni.com/environment/weee.

电子信息产品污染控制管理办法（中国 RoHS）



中国客户 National Instruments 符合中国电子信息产品中限制使用某些有害物质指令 (RoHS)。关于 National Instruments 中国 RoHS 合规性信息，请登录 ni.com/environment/rohs_china。(For information about China RoHS compliance, go to ni.com/environment/rohs_china.)

Refer to the *NI Trademarks and Logo Guidelines* at ni.com/trademarks for information on NI trademarks. Other product and company names mentioned herein are trademarks or trade names of their respective companies. For patents covering NI products/technology, refer to the appropriate location: **Help»Patents** in your software, the `patents.txt` file on your media, or the *National Instruments Patent Notice* at ni.com/patents. You can find information about end-user license agreements (EULAs) and third-party legal notices in the readme file for your NI product. Refer to the *Export Compliance Information* at ni.com/legal/export-compliance for the NI global trade compliance policy and how to obtain relevant HTS codes, ECCNs, and other import/export data. NI MAKES NO EXPRESS OR IMPLIED WARRANTIES AS TO THE ACCURACY OF THE INFORMATION CONTAINED HEREIN AND SHALL NOT BE LIABLE FOR ANY ERRORS. U.S. Government Customers: The data contained in this manual was developed at private expense and is subject to the applicable limited rights and restricted data rights as set forth in FAR 52.227-14, DFAR 252.227-7014, and DFAR 252.227-7015.

© 2010—2015 National Instruments. All rights reserved.